

MML 144/30-LS 144 MHz 30 WATT LINEAR AMPLIFIER

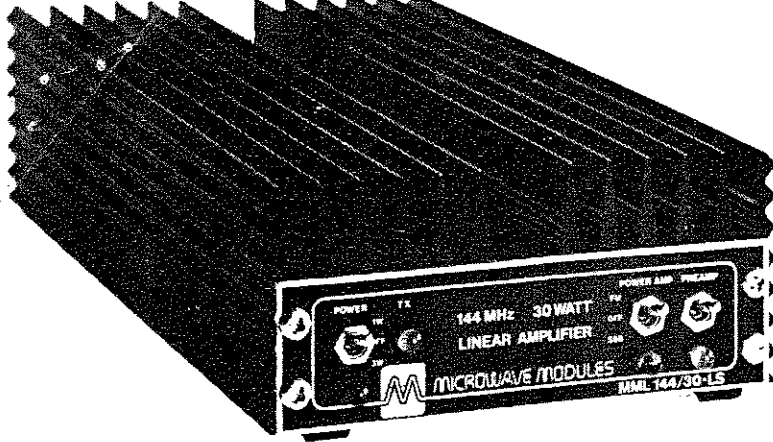

FEATURES

- 30 WATTS OUTPUT POWER.
- SUITABLE FOR 1 OR 3 WATT TRANSCEIVERS.
- LINEAR ALL MODE OPERATION.
- STRAIGHT THROUGH OPERATION WHEN TURNED OFF.
- ULTRA-LOW NOISE RECEIVE PREAMPLIFIER — FRONT PANEL SELECTABLE.
- EQUIPPED WITH RF VOX AND MANUAL OVERRIDE.
- LED STATUS LIGHTS FOR POWER, TRANSMIT AND PREAMP ON.

SPECIFICATION

Linear Amplifier

Power output	: 30 watts \pm 1 dB
Power input	: 1 or 3 watts for full output Front panel selectable
Frequency bandwidth	: 144-146 MHz at -1 dB
Power requirements	: 13.8V DC at 4 Aamps
Quiescent current	: 800mA (with zero drive)

Receive Preamp

Overall gain	: 12 dB typical
Overall noise figure	: Better than 1.5 dB
Frequency bandwidth	: 144-146 MHz at -1 dB
Receive current	: 200mA

General

RF connectors	: SO239
Size	: 205x115x55 mm
Weight	: 1.5 Kg

DESCRIPTION

This 144 MHz solid state linear amplifier, MML 144/30-LS has been introduced as a result of the advent of the many popular 1 and 3 watt 2 metre transceivers currently available.

When used in conjunction with such equipment this linear amplifier will provide an output power of 30 watts. An internal attenuator, controlled by a front panel mounted switch, allows both 1 and 3 watt input levels, thereby affording maximum versatility. Several other switches controlling the internal switching circuitry, allow the unit to be left in circuit at all times. The linear power amplifier and low-noise receive preamplifier can both be independently switched in and out of circuit. In this way, all four operational combinations are possible.

By means of an RF vox circuit the linear will automatically switch on to transmit, when 144 MHz drive is applied to the input socket. It is possible to override this facility by the connection of an earth to the phono socket located on the rear panel. This connection is compatible with all current transceiver PTT lines. The RF vox has switched delay times for SSB and FM modes.

The inclusion of the latest state of the art power transistor (rated at 65W dissipation) guarantees highly reliable and ultra-linear performance, thus making the unit ideal for all modes of operation. (SSB, FM, AM & CW). The PA transistor is thermally tracked against temperature variation and operational temperature rise.

The receive preamplifier uses one of the latest dual gate FETs in a noise matched configuration. This technique, together with careful optimisation of overall gain, makes the preamplifier ideal for use ahead of any popular 2 meter transceiver. The sensitivity of current 2 metre transceivers is such that a preamplifier gain of 12 dB is sufficient to ensure an excellent overall system noise figure. A preamplifier with gain in excess of this figure will prove unduly detrimental to the strong signal-handling performance of the transceiver.

All circuitry is constructed on high quality glass-fibre printed circuit board and protection is included against reverse polarity. The unit is housed in a highly durable extruded aluminium enclosure, RF connectors are located on the rear panel together with the power lead and PTT phono socket.

All necessary plugs are supplied.



MICROWAVE MODULES LTD.

Brookfield Drive, Aintree, Liverpool L9 7AN, England.
Telephone: 051-523 4011. Telex: 628608 MICRO G.



MICROWAVE MODULES LIMITED

Radio Consultants and Manufacturers
Brookfield Drive, Aintree, Liverpool L9 7AN, England
Telephone: 051-523 4011. Telex: 628608 MICRO G

INTRODUCTION

The MML144/30-IS is a high performance solid-state linear power amplifier, and has been designed to provide 30 watts power output when used in conjunction with an existing 144 MHz transceiver.

Now that you are the proud owner of this Microwave Modules product, you will be expecting the usual quality and performance associated with our name.

To achieve this performance and reliability, please read the following instructions fully before attempting to put the product into service.

ACCESSORIES

Please check that, in addition to these instructions, the amplifier is accompanied by the following accessories :

PL259 Plug	2 off
Phono Plug	1 off

INSTALLATION

1) General

The amplifier should be kept from extremes of heat/cold and humidity. Choose an operating point that is dry, cool and do not operate the unit in direct sunlight. The amplifier is rated for ICAS service (Intermittent Commercial and Amateur Service). We recommend a maximum transmit duty cycle of 50 percent, with a maximum transmit period of 15 minutes at full power in the FM mode.

2) Power Supplies

A well-regulated and stabilised DC power supply is essential for reliable and trouble-free operation. In a mobile situation, the vehicle battery is ideal for providing the DC required by the amplifier. In a fixed station environment, however, should a car battery be used for powering the amplifier, we do not recommend that a mains-powered battery charger should be connected to the battery at the same time as the amplifier.

In all cases, extreme care should be taken to avoid reverse polarity of the supply.

Any mains power supply which is chosen should be adequately rated to cater for the current consumption of the amplifier and of any other equipment connected to the power supply at the same time.

In our experience of manufacturing and supplying many thousands of solid-state amplifiers to a world-wide market over the past ten years or so, the majority of failures are due to the use of badly-designed power supplies. Typical deficiencies of poorly-designed power supplies are :

- a) the generation of very fast high voltage spikes which appear on the DC supply to the amplifier
- b) a sensitivity to the presence of RF which severely affects the stability of the power supply voltage, with disastrous results.

3) Antennas

The antenna system presented to the output of the linear amplifier should have a VSWR of 1.5 to 1, or better if possible. If this is not the case, it is advisable to take steps to reduce the VSWR of the antenna system, to ensure a better impedance match which will maintain reliability of the amplifier.

Antennas must be fed with 50 ohm coaxial cable, and care should be taken when fitting the connectors to the cable. An intermittent or poorly-soldered connection can cause serious damage, and we cannot over-emphasise the importance of checking all such connections.

Antennas should not be located close to the transceiver, the power supply, or the amplifier. As mentioned above, strong RF fields can cause power supply problems, or at the very least can give rise to system feedback which will greatly reduce the quality of the transmitted signal.

4) Delay Time for RF Vox (SSB Mode only)

Your amplifier includes an internal adjustment to allow the user to change the time constant in the RF Vox circuitry, to suit individual preference. As supplied, the amplifier has been factory-set on production, with a delay time (transmit mode to receive mode) of about one half second. The adjustment as described below allows the delay time to be adjusted continually over the range zero to 2.5 seconds.

When switched to SSB, the amplifier may be adjusted to increase or decrease the delay time as follows :

- a) Remove the four screws holding the front panel in place, ensuring that AT NO TIME do any of the switch connections come into contact with the heatsink.
- b) Gently ease forward the front panel away from the heatsink, and slide forward the amplifier base-plate.
- c) Place the unit as shown in the diagram below, and locate the preset potentiometer marked 'V' on the diagram.
- d) Rotating this potentiometer will vary the delay according to preference.
- e) Replace the baseplate, and relocate the front panel taking great care not to trap any wires.

IMPORTANT: Take extreme care not to adjust any other variable components as this will invalidate your guarantee.

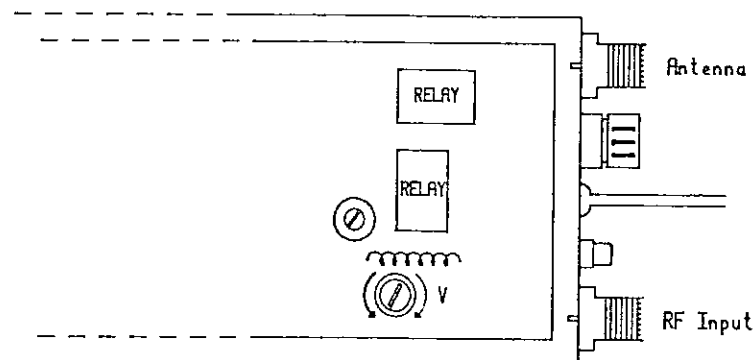

5) Interconnecting Cables

a) The coaxial cable between the transceiver and the amplifier should be made using UR43 cable, and experience has shown that problems of mismatch during switching periods are minimised by using a length of approximately 4 feet.

b) The push-to-talk (PTT) connection, when used instead of the RF Vox facility, should be made of screened cable. The length of this cable is not at all critical, but it is suggested that it should be screened since certain transceivers are prone to feedback if RF is picked up on the PTT line.

6) RF Input Levels

It is important not to overdrive the input of the amplifier, otherwise damage may occur to the input components, including possibly the RF transistors.

Often such problems may not be the direct fault of the user, since certain Japanese transceivers produce considerably more output power than specified. If in doubt, first check the output power of your equipment before connecting the amplifier.

7) And Finally

In our experience, most problems or suspected problems are generally attributable to system difficulties rather than individual items. If you have followed the advice above, and connected the equipment properly, no problems should be encountered.

If after checking thoroughly, you do have a problem, then please contact either your supplier or the factory direct.

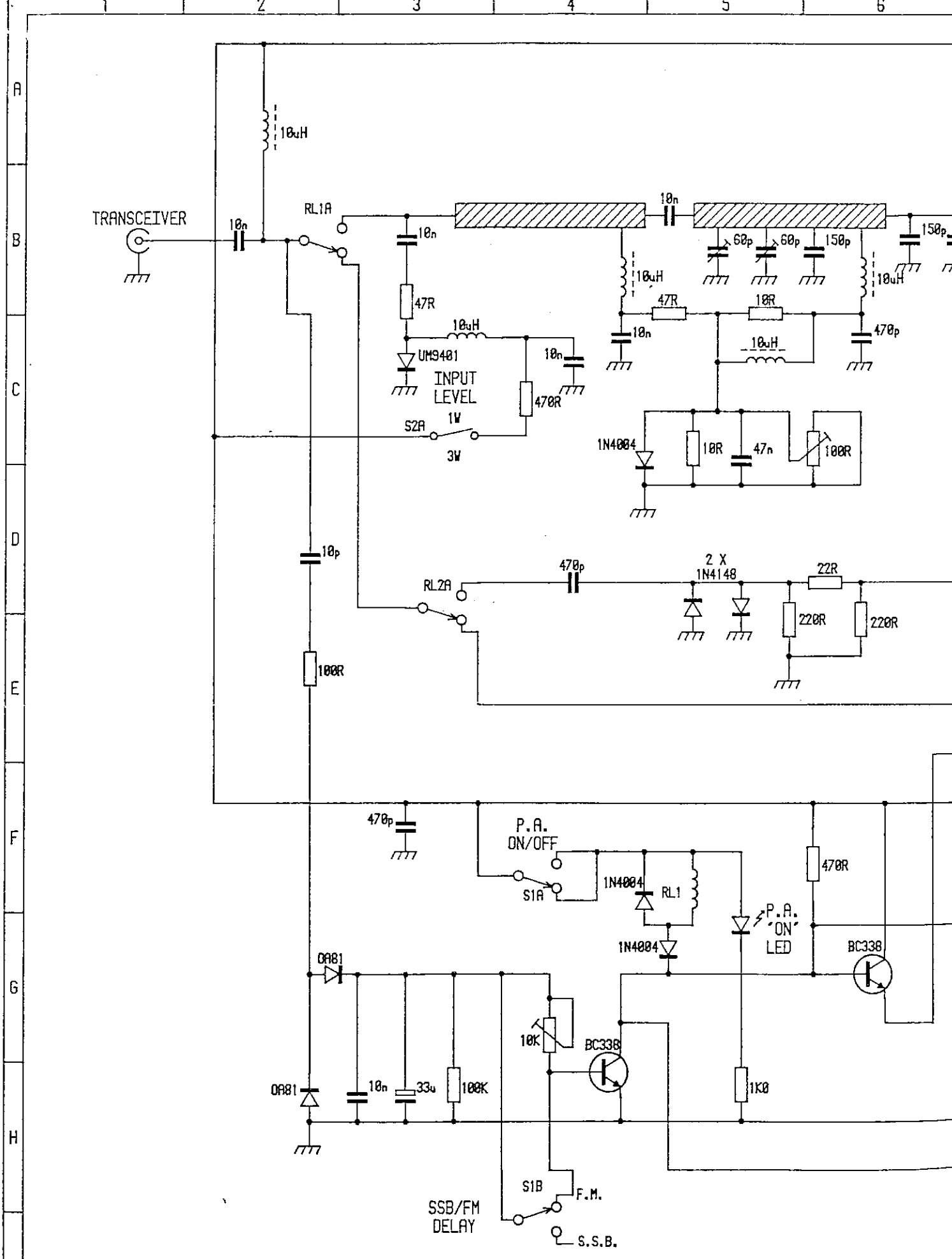

ISSUE	1	2	3	4	5	6	7	8	9	10
DATE	19/11/66									
APPD	EG									



MICROWAVE MODULES LTD

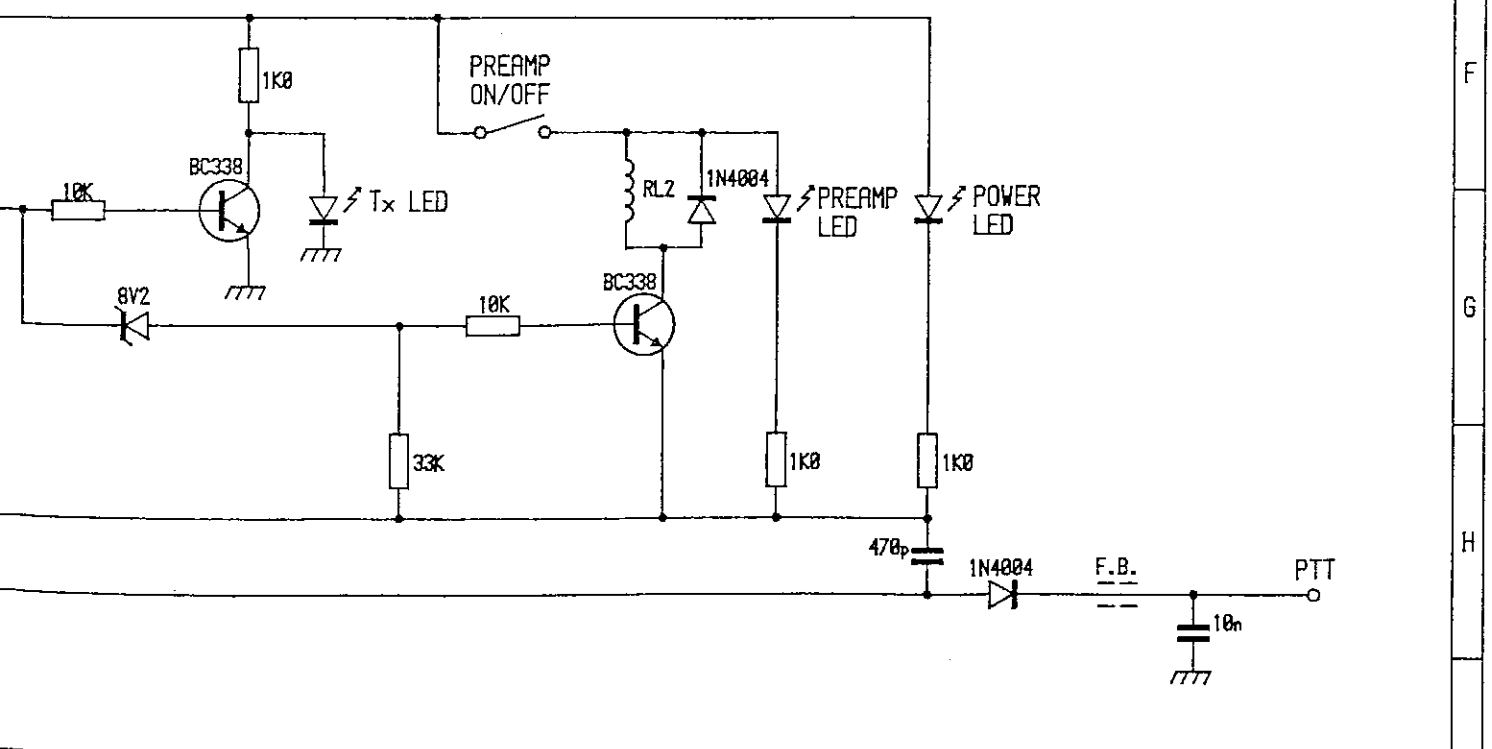
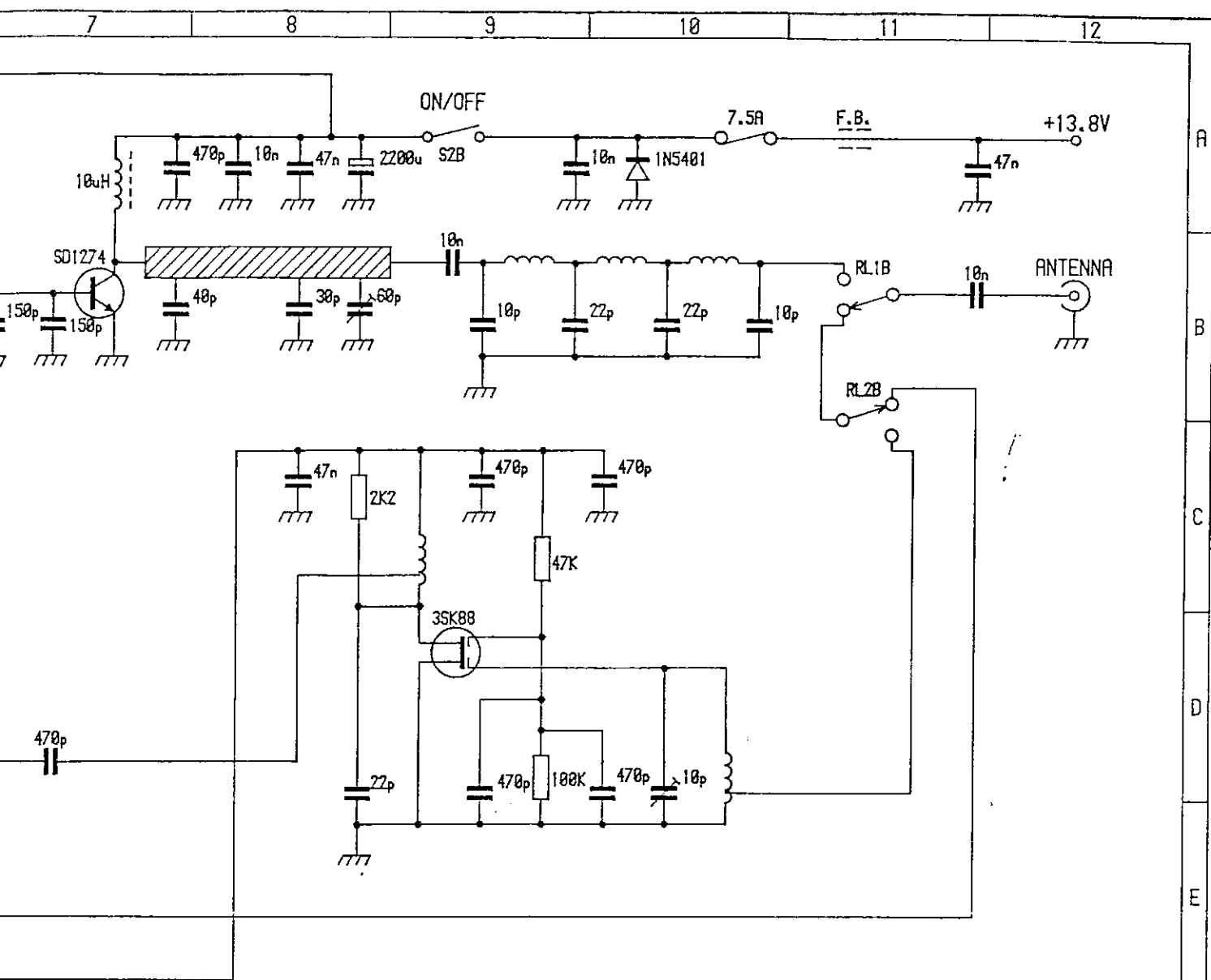

TITLE	DRAWN AMC	DATE 19/11/86	APPD J.R.
MML144/30-LS	PART OF MML144/30-LS	SHEET 1 OF 1	
144MHz 30 WATT LINEAR AMPLIFIER			
DRAWING No. 854310			